

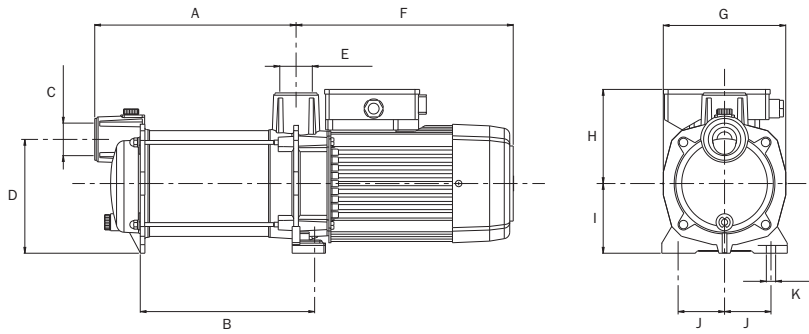

# Prisma35 N

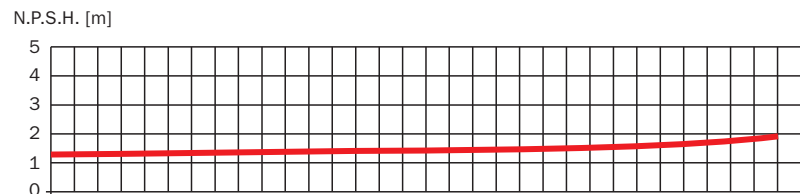

	A	B	C	D	E	F	G	H	I	J	K	Kg
Prisma35 3 N	221.1	187.3	1 1/2"	147	1 1/2"	281.5	158	125.3	90	60	12	18.5/18.2
Prisma35 4 N	246.6	211.8	1 1/2"	147	1 1/2"	281.5	158	125.3	90	60	12	20.5/18.6
Prisma35 5 N	271.1	236.3	1 1/2"	147	1 1/2"	281.5	158	125.3	90	60	12	23.5/20.6
Prisma35 6 N	295.6	260.8	1 1/2"	147	1 1/2"	281.5	158	125.3	90	60	12	23.7

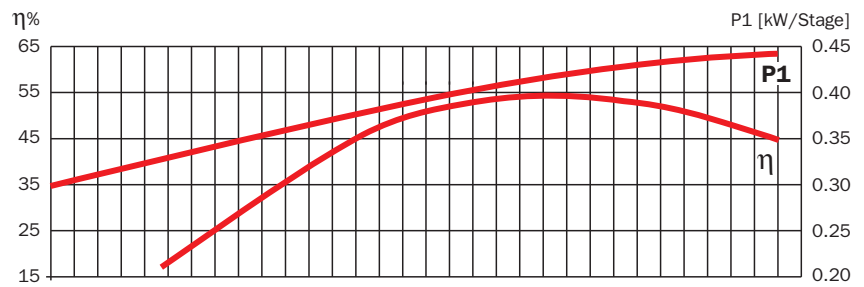
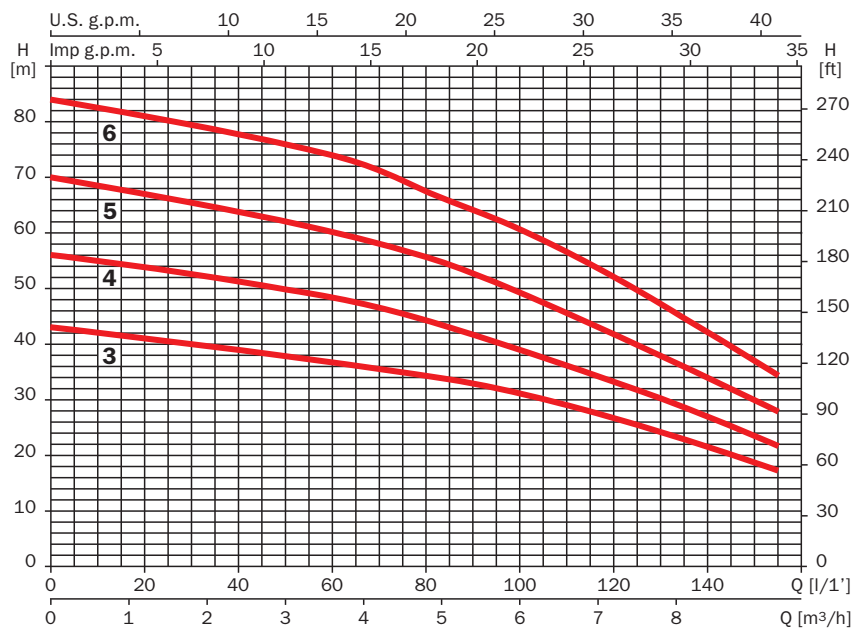

Curvas de funcionamiento a 2900 r.p.m.  
 Performance curves at 2900 r.p.m.

230 V 50 Hz	230/400 V 50 Hz	A			P1 (kW)		kW	HP	μF	L/1' m³/h	20	40	60	80	100	120	140	150
		1~ 230 V	3~ 230 V	3~ 400 V	1~	3~												
Prisma35 3M N	Prisma35 3 N	6.7	4.5	2.6	1.5	1.4	0.8	1	25		41	39	36	34	31	27	22	18
Prisma35 4M N	Prisma35 4 N	8.4	5.3	3.1	1.8	1.8	1.1	1.5	25		54	51	48	44	39	33	27	23
Prisma35 5M N	Prisma35 5 N	10.2	6.9	4	2.3	2.2	1.5	2	30		68	64	60	55	49	41	34	30
	Prisma35 6 N	-	8.3	4.8	-	2.7	2.2	3	-		81	78	74	67	60	52	42	37